

Hoshizaki America, Inc.

Cubelet Icemaker/Dispenser

Models

DCM-300BAH(-OS)



“A Superior Degree
of Reliability”

www.hoshizaki.com

PARTS LIST



Number: 71326
Issued: 4-20-2011

CONTENTS

Auxiliary Codes.....	3
Note About Ordering Parts	3
A. Ice Dispenser Assembly	4
B. Refrigeration Circuit.....	7
C. Ice Making Unit	9
D. Water Circuit	11
E. Control Box Assembly.....	13
F. Shutter Assembly	14
G. Dispensing & Agitating Gear Motor Assemblies	15
H. Bin Assembly.....	16
J. Label Location.....	17
K. Accessories & Packaging	18

Auxiliary Codes

DCM-300BAH A-0 April 2011

DCM-300BAH-OS A-0 April 2011

Auxiliary Code Breakdown

The auxiliary code is the first two characters in the serial number. The first character indicates the year. Years progress or regress in alphabetical order. The series runs from "A" through "V" and the letters "I" and "O" are skipped. The second character indicates significant part changes within a year. Base is "0" and this number advances for each change. In cases where there is a letter in parentheses, this designates the month. This is the last character in the serial number. The series runs from "(A)" through "(M)" and the letter "(I)" is skipped. This designation is only included when identifying a parts change within an auxiliary code.

Note About Ordering Parts

Most assemblies cannot be ordered as complete units; parts in the assemblies generally must be ordered separately.

A. Ice Dispenser Assembly

DCM-300BAH, DCM-300BAH-OS

A-0

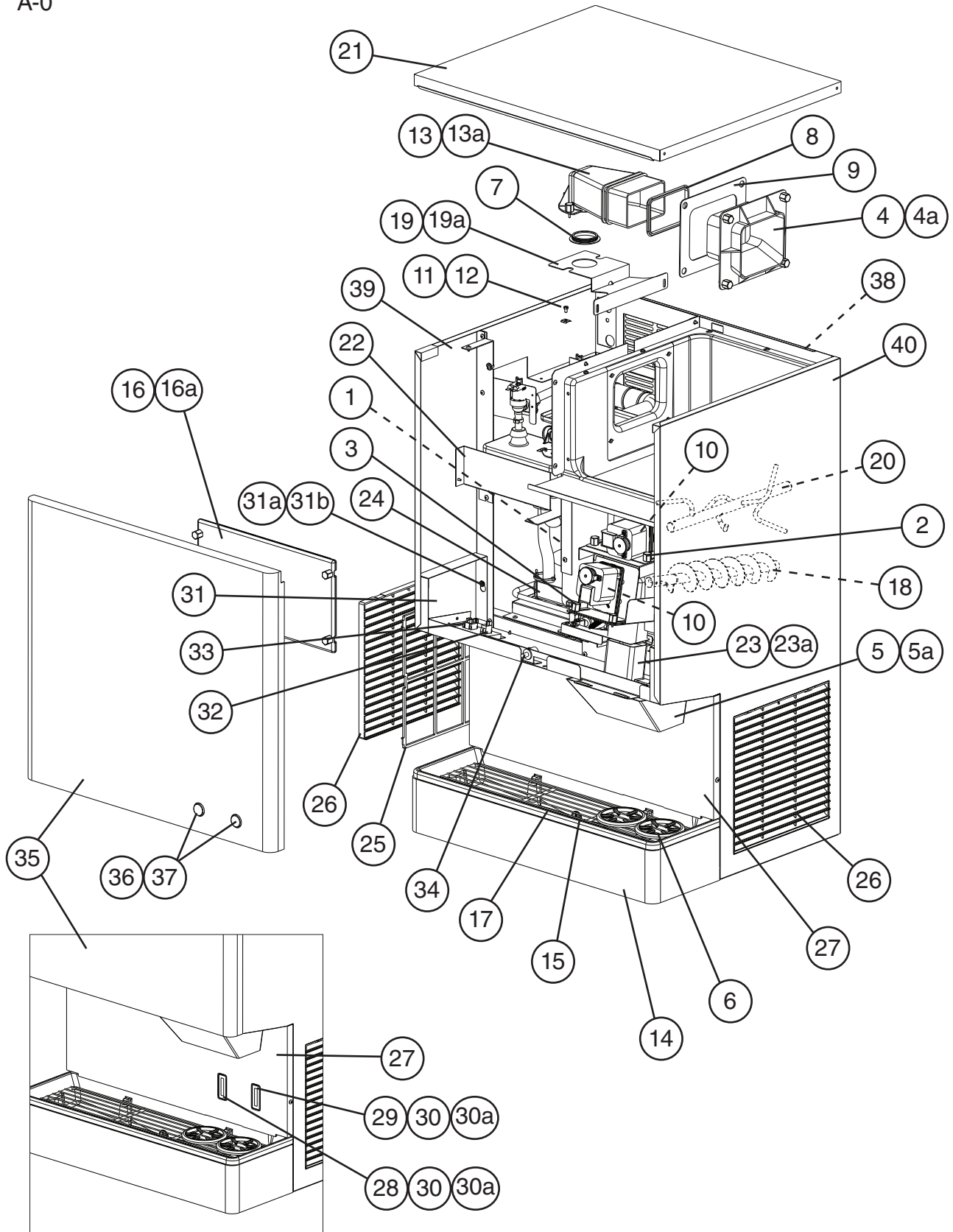

DCM-300BAH-OS

Title: A. Ice Dispenser Assembly Model: DCM-300BAH, DCM-300BAH-OS												
Index No.	Description	Material or Model Number	Part Number	Required Number								
				A-0								
Ice Dispenser Assembly		DCM-300BAH	1A2196A01	1								
Order Assembly Parts Individually		DCM-300BAH-OS	1A2196A02	1								
1	Socket Hex Cap Screw	8x95, SS	7S12-0895	3								
2	Thumbscrew		415949G12	3								
3	Thumbscrew		415949G12	3								
4	Spout B		208807-01	1								
4a	Thumbscrew		415949G11	4								
5	Spout Cover		215773-01	1								
5a	Thumbscrew		415949G08	2								
6	Cup Guide		326702-01	2								
7	Packing		427151-01	1								
8	Spout Packing A		427195-01	1								
9	Spout Packing B		427196-01	1								
10	Gasket		429758-01	2								
11	Ground Screw		433304-02	1								
12	Square Washer		433537-02	1								
13	Spout		3A6554-01	1								
13a	Thumbscrew		415949G11	3								
14	Lower Panel		2A0699G01	1								
15	Grille		2A0827G01	1								
16	Bin Cover		2A0880A02	1								
16a	Thumbscrew		415949G12	4								
17	Drip Tray		2A2591G01	1								
18	Auger		339192G01	1								
19	Evaporator Bracket		3A6580-01	1								
19a	Hex Head Bolt w/Washer	5x10, SS	7B0230510	2								
20	Agitator		3A0895G01	1								
21	Top Panel		3A2514G01	1								
22	Reservoir Bracket		3A5675-01	1								
23	Ice Chute		4A2204-01	1								
23a	Thumbscrew		415949G08	2								
24	Drain Pan		323765G01	1								
25	Air Filter		208283G03	1								
26	Louver		103121-03	2								
27	Apron Panel	DCM-300BAH	2A0720-01	1								
		DCM-300BAH-OS	3A3617G01	1								
28	Ice Sensor Assembly	DCM-300BAH-OS	4A3753G01	1								
29	Water Sensor Assembly	DCM-300BAH-OS	4A3753G02	1								
30	Sensor Latch	DCM-300BAH-OS	4A3848-01	2								
30a	Thumbscrew	DCM-300BAH-OS	415949G10	2								
31	Middle Front Frame	DCM-300BAH	2A4748G01	1								
		DCM-300BAH-OS	2A2743G01	1								
31a	Taper Collar		4H0171-01	2								
31b	Flat Head Screw	4x12, SS	7C22-0412	2								

Title: A. Ice Dispenser Assembly Model: DCM-300BAH, DCM-300BAH-OS												
Index No.	Description	Material or Model Number	Part Number	Required Number								
				A-0								
32	Dispense Mode Switch	DCM-300BAH	4A0558-01	1								
		DCM-300BAH-OS	4A2957-01	1								
33	Control Switch		4A1034-01	1								
34	Safety Switch		4A5034-01	1								
35	Front Panel Assembly (includes items 36 and 37)	DCM-300BAH	3A4999A02	1								
	Front Panel	DCM-300BAH-OS	2A2891-01	1								
36	Push Switch Assembly (includes item 37)	DCM-300BAH	3A4997A01	1								
37	Push Switch	DCM-300BAH	435745-02	2								
38	Rear Panel		2A5403-01	1								
39	Left Side Panel		2A6144-01	1								
40	Right Side Panel		2A6143-02	1								

B. Refrigeration Circuit
DCM-300BAH, DCM-300BAH-OS
A-0

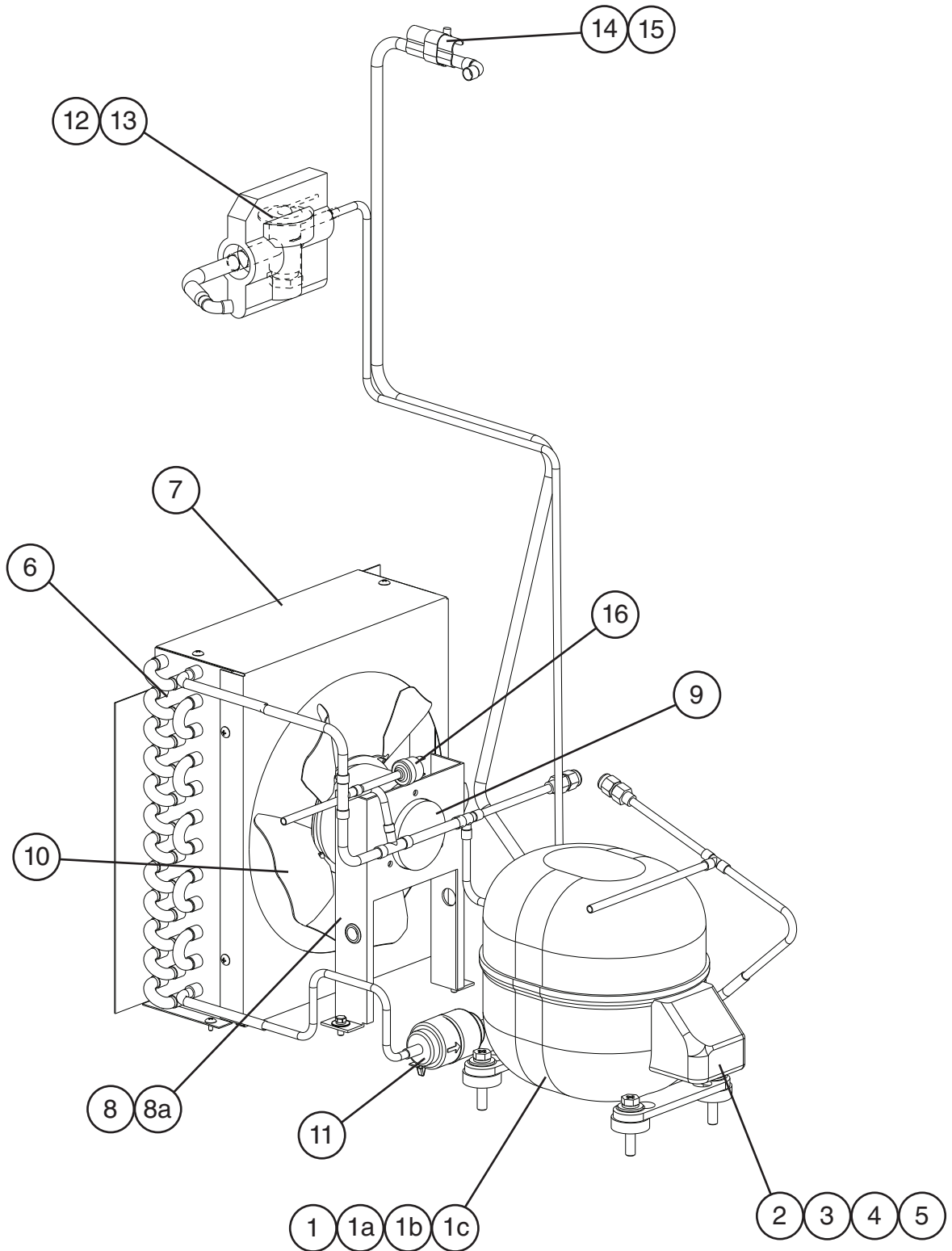

Title: B. Refrigeration Circuit Model: DCM-300BAH, DCM-300BAH-OS												
Index No.	Description	Material or Model Number	Part Number	Required Number								
				A-0								
Refrigeration Circuit Order Assembly Parts Individually			2A6525A01	1								
1	Compressor (includes items 2 through 5)		4A4614-01	1								
1a	Grommet		4A2281-01	4								
1b	Spacer		4A2282-01	4								
1c	Bolt	8x45	437889-01	4								
2	Terminal Box		4A4614F01	1								
3	Protector Retainer		4A4614F02	1								
4	Protector		4A4614F03	1								
5	Start Relay		4A4614F04	1								
6	Condenser		2A0780-01	1								
7	Fan Shroud		3A0715-01	1								
8	Fan Motor Bracket		3A0716-01	1								
8a	Hex Head Bolt w/Washer	5x12, SS	7B0230512	2								
9	Fan Motor		4A0815-01	1								
10	Fan Blade		3A0608-01	1								
11	Drier		4A1113-01	1								
12	Expansion Valve		4A1117-01	1								
13	Expansion Valve Cover		4A1168-01	1								
14	Expansion Valve Bulb Holder		3A0107-01	1								
15	Clamp		443461-01	1								
16	High-Pressure Switch		463180-04	1								

C. Ice Making Unit
DCM-300BAH, DCM-300BAH-OS
A-0

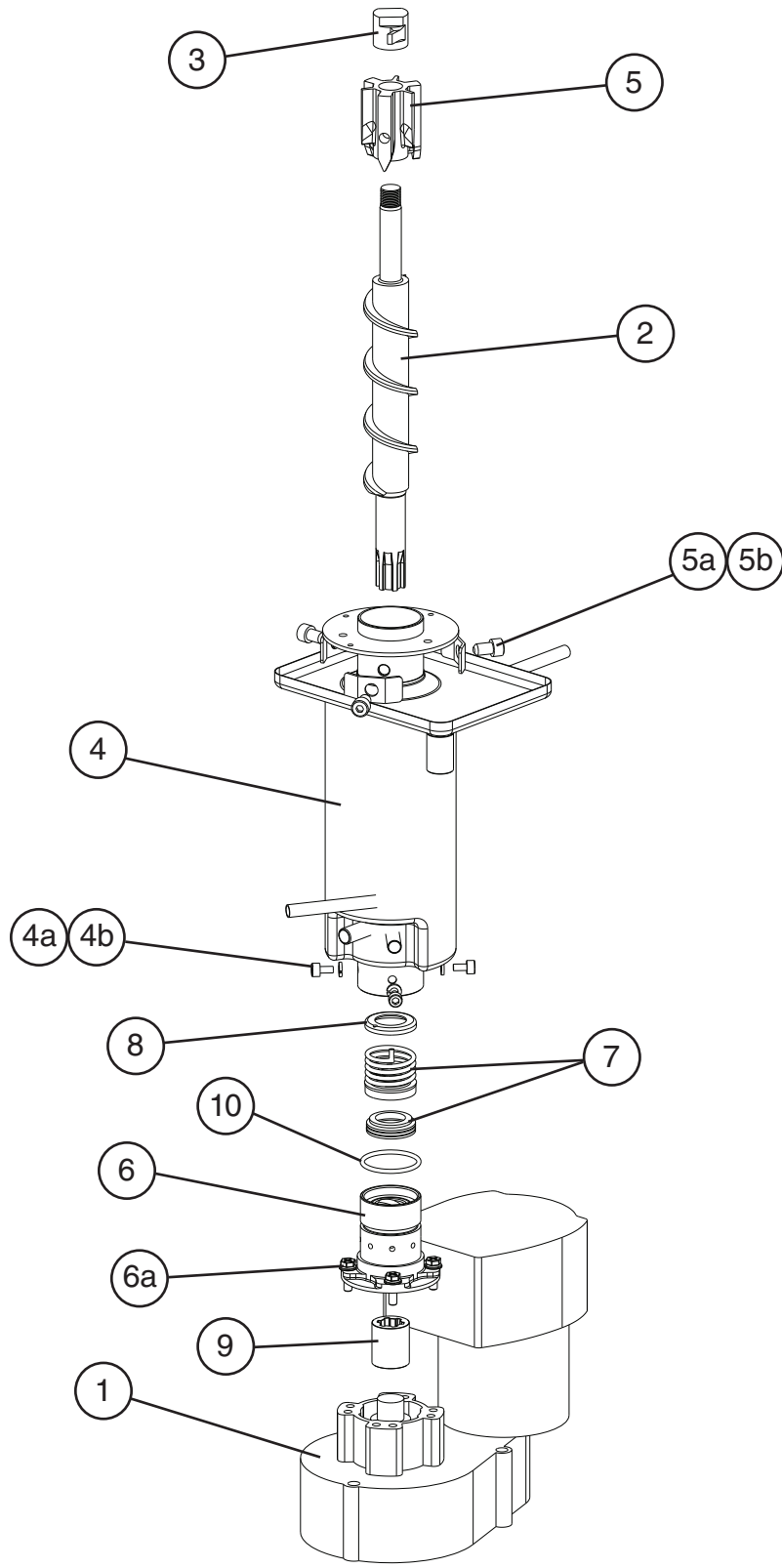

Title: C. Ice Making Unit Model: DCM-300BAH, DCM-300BAH-OS												
Index No.	Description	Material or Model Number	Part Number	Required Number								
				A-0								
Ice Making Unit Order Assembly Parts Individually			3A6561A01	1								
1	Gear Motor (for mounting hardware, see section "A" item 1)		2U0147-01	1								
2	Auger		361013G01	1								
3	Cutter		440905-01	1								
4	Evaporator		2A3308G01	1								
4a	Split Lock Washer	M6, SS	7L22-0600	4								
4b	Socket Head Cap Screw	6x10, SS	7S12-0610	4								
5	Extruding Head		327141G01	1								
5a	Seal Bolt	M8	P01768-01	3								
5b	Washer		453791-01	3								
6	Housing		206013G03	1								
6a	Bolt	6x20, SS	4A1989-01	4								
7	Mechanical Seal		432491-01	1								
8	Ring		432494-01	1								
9	Spline Coupling		418316-01	1								
10	"O" Ring		4A4755-01	1								

D. Water Circuit
DCM-300BAH, DCM-300BAH-OS
A-0

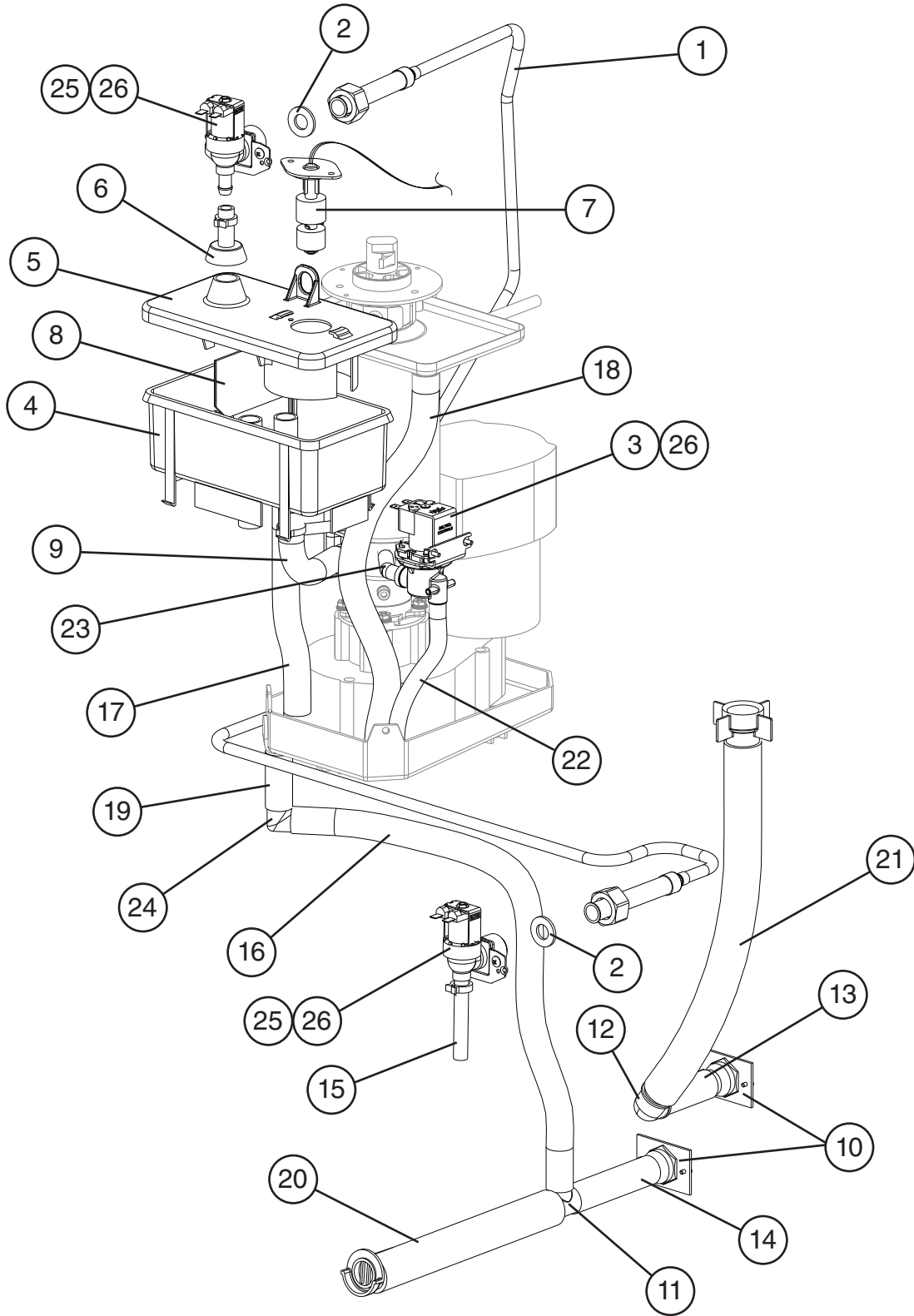

Title: **D. Water Circuit** Model: **DCM-300BAH, DCM-300BAH-OS**

Index No.	Description	Material or Model Number	Part Number	Required Number																
				A-0																
Water Circuit Order Assembly Parts Individually			2A6533A02	1																
1	Water Supply Pipe		2A0680G01	1																
2	Washer		4A0867-01	2																
3	Drain Valve		4A2772-01	1																
4	Reservoir		2A0753-01	1																
5	Reservoir Cover		214810-01	1																
6	Reservoir Inlet		4A0869-01	1																
7	Float Switch		435490-01	1																
8	Reservoir Separator		4A1255-01	1																
9	Reservoir Hose		4A1165-12	1																
10	Fitting		4A0776G01	2																
11	Tee		4A0525-04	1																
12	Elbow		4A1016-01	1																
13	Vinyl Hose	L=60	7716-2025	1																
14	Vinyl Hose	L=100	7716-2025	1																
15	Vinyl Hose	L=75	7725-0912	1																
16	Vinyl Hose	L=500	7725-1923	1																
17	Vinyl Hose	L=260	7725-1923	1																
18	Vinyl Hose	L=390	7725-1923	1																
19	Vinyl Hose	L=50	7725-1923	1																
20	Vinyl Hose	L=225	4A0658L01	1																
21	Vinyl Hose	L=380	4A0658L01	1																
22	Silicone Hose	L=170	7730I3896	1																
23	Silicone Hose	L=50	7730I3896	1																
24	Elbow		4A1017-01	1																
25	Inlet/Dispense Water Valve		4A0865-01	2																
26	R-C Capacitor (Noise Killer)	0.2MFD, 250VAC	4A1012-01	3																
Clamps																				
	Hose Clamp		4A2017-05	1																
	Hose Clamp		4A2017-08	3																

E. Control Box Assembly

DCM-300BAH, DCM-300BAH-OS

A-0

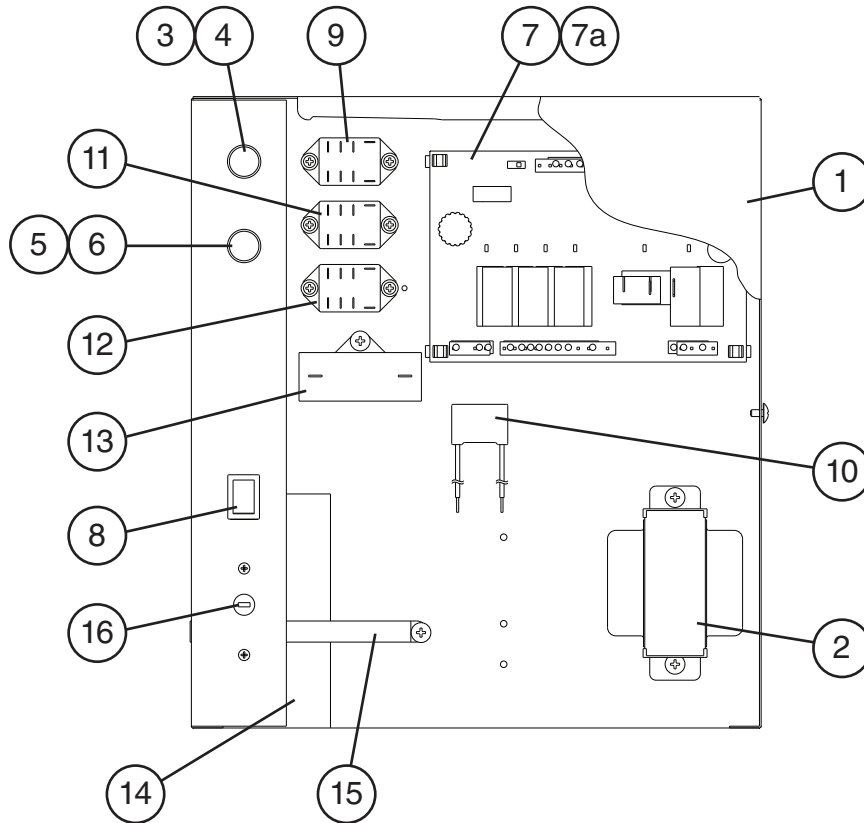

Title: E. Control Box Assembly Model: DCM-300BAH, DCM-300BAH-OS												
Index No.	Description	Material or Model Number	Part Number	Required Number								
				A-0								
Control Box Assembly		DCM-300BAH	2A6524A01	1								
Order Assembly Parts Individually		DCM-300BAH-OS	2A6524A02	1								
1	Control Box Cover		4A5054-01	1								
2	Transformer		2U0042-02	1								
3	Fuse Holder		4A3449-01	1								
4	Transformer 24V Circuit Fuse	1A, 250VAC	4A0893-01	1								
5	Fuse Holder		4A3449-02	1								
6	Transformer 10.5V Circuit Fuse	500mA, 250VAC	4A0893-02	1								
7	Control Board	DCM-300BAH	2A1592-01	1								
		DCM-300BAH-OS	2A2649-01	1								
7a	Board Support		4A0336-03	4								
8	Power Switch		4A0558-01	1								
9	Water Control Relay		406132-03	1								
10	R-C Capacitor (Noise Killer)	0.2MFD, 250VAC	4A1012-01	1								
11	Gear Motor Protect Relay		406132-07	1								
12	Power Protect Relay		418271-05	1								
13	Gear Motor Capacitor	10MFD, 280VAC	416921-05	1								
14	Start Capacitor	145-175MFD, 250VAC	3A0076-01	1								
15	Strap		4A2262-02	1								
16	Gear Motor Protector (overload)		427253-01	1								

F. Shutter Assembly
DCM-300BAH, DCM-300BAH-OS
 A-0

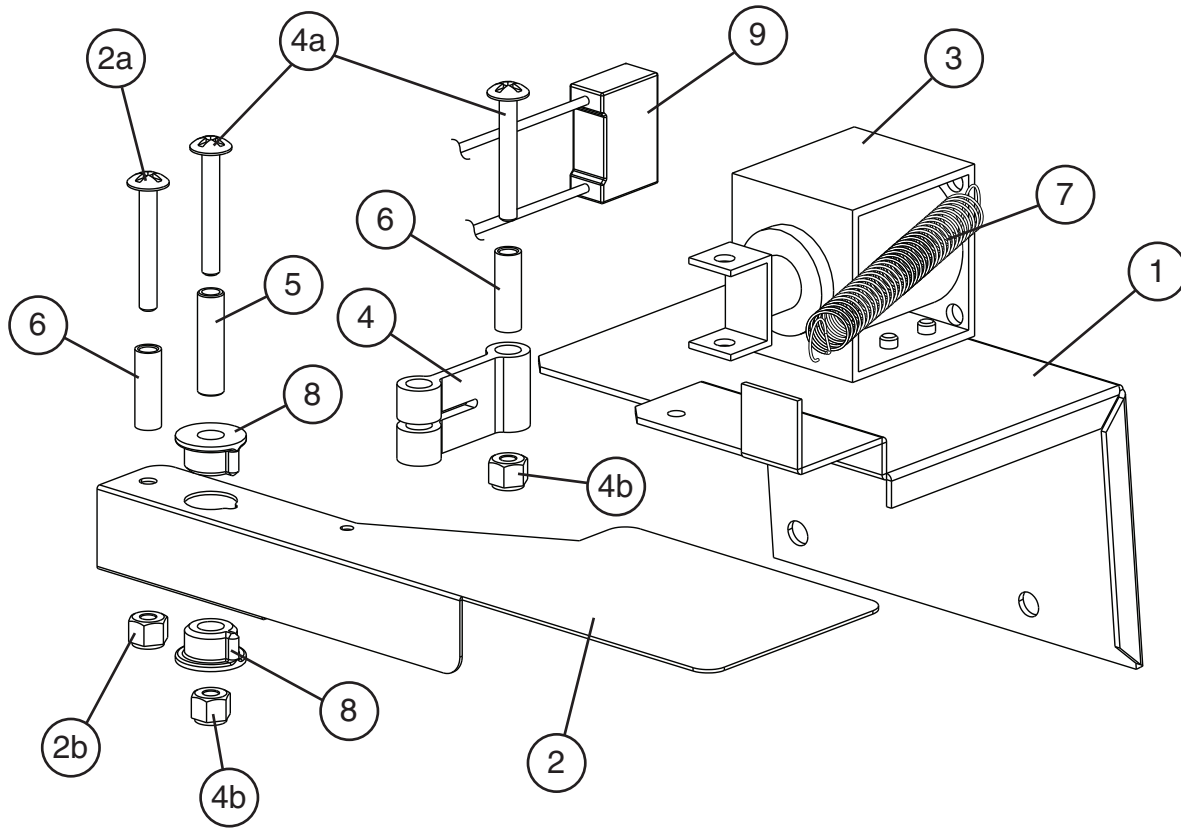

Title: F. Shutter Assembly		Model: DCM-300BAH, DCM-300BAH-OS		Required Number										
Index No.	Description	Material or Model Number	Part Number	A-0										
Shutter Assembly			2A6131A01	1										
1	Base		3A6138-01	1										
2	Lever		3A6139-01	1										
2a	Truss Head Screw	4x30, SS	7C32-0430	1										
2b	Self-Locking Nut	M4, SS	7N22-0400	1										
3	Solenoid		4A0856-01	1										
4	Link		432232-01	1										
4a	Truss Head Screw	4x30, SS	7C32-0430	2										
4b	Self-Locking Nut	M4, SS	7N22-0400	2										
5	Collar		432240-02	1										
6	Collar D		432471-01	2										
7	Spring		432878-01	1										
8	Shutter Collar		435533-01	2										
9	R-C Capacitor (Noise Killer)	0.2MFD, 250VAC	4A1012-01	1										

G. Dispensing & Agitating Gear Motor Assemblies

DCM-300BAH, DCM-300BAH-OS

A-0

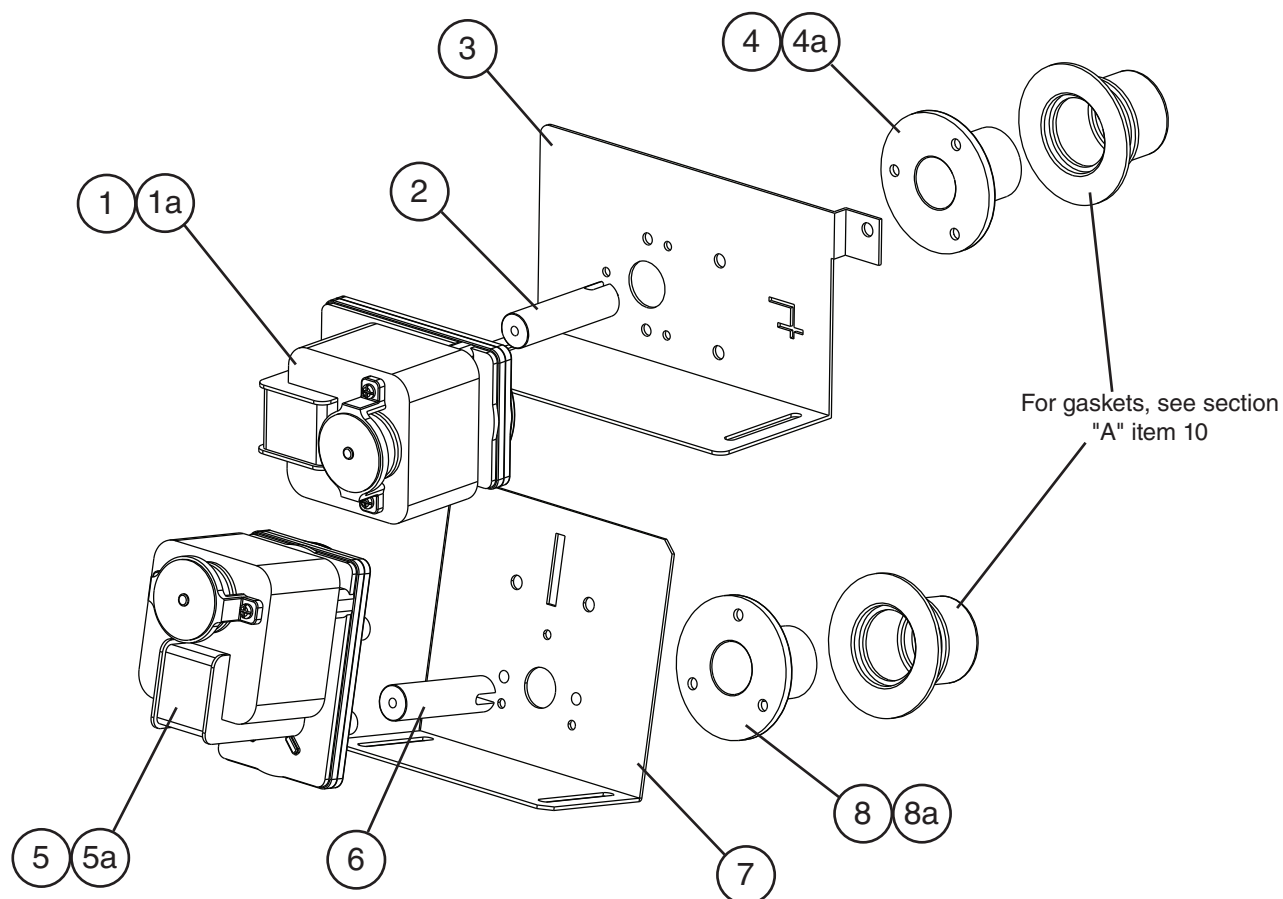

Title: G. Dispensing & Agitating Gear Motor Assemblies Model: DCM-300BAH, DCM-300BAH-OS																		
Index No.	Description	Material or Model Number	Part Number	Required Number														
				A-0														
Agitating Motor Assembly																		
	4A0620A01			1														
1	Agitating Gear Motor		2U0080-01	1														
1a	Flat Head Screw	4x6, SS	7C22-0406	4														
2	Joint		429764-01	1														
3	Agitating Gear Motor Bracket (for mounting hardware, see section "A" item 2)		4A0618-01	1														
4	Plastic Sleeve		429761-01	1														
4a	Flat Head Screw	4x8, SS	7C22-0408	3														
Dispensing Motor Assembly																		
	4A0622A01			1														
5	Dispensing Gear Motor		2U0080-03	1														
5a	Flat Head Screw	4x6, SS	7C22-0406	4														
6	Joint		429764-01	1														
7	Dispensing Gear Motor Bracket (for mounting hardware, see section "A" item 3)		3A0361-01	1														
8	Plastic Sleeve		429761-01	1														
8a	Flat Head Screw	4x8, SS	7C22-0408	3														

H. Bin Assembly
DCM-300BAH, DCM-300BAH-OS
 A-0

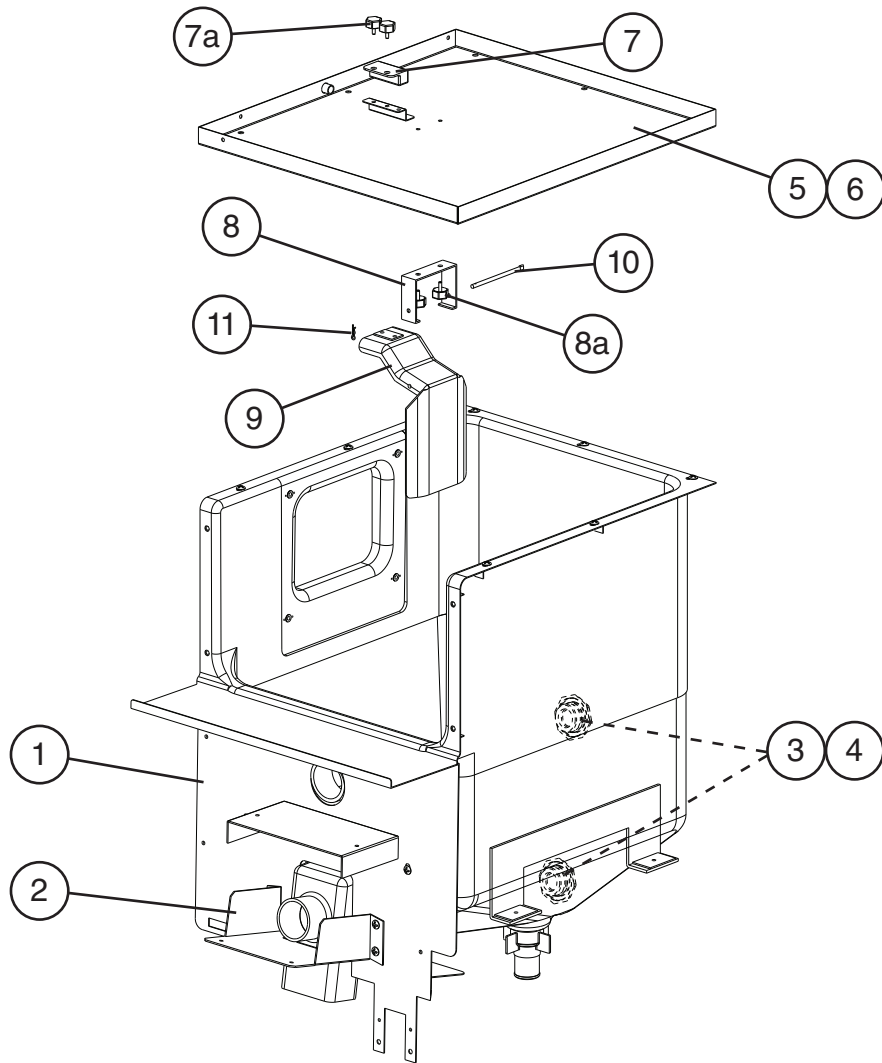

Title: H. Bin Assembly Model: DCM-300BAH, DCM-300BAH-OS										
Index No.	Description	Material or Model Number	Part Number	Required Number						
				A-0						
Bin Assembly			2A0413A02	1						
1	Barrier		2A5487G01	1						
2	Sliding Bracket		3A0364-01	1						
3	Shaft Holder		429818-01	2						
4	"O" Ring		7616-P032	2						
5	Bin Top Assembly (includes items 6 through 11)		3A1565A01	1						
6	Bin Top Cover		2A1716G01	1						
7	Mechanical Bin Control Proximity Switch		4A2033-01	1						
7a	Thumbscrew		415949G08	2						
8	Bin Control Bracket (Hinge)		3A0762-01	1						
8a	Thumbscrew		415949G08	2						
9	Actuator		208795G01	1						
10	Shaft		412337-03	1						
11	Snap Pin		715S-0004	1						

J. Label Location

DCM-300BAH, DCM-300BAH-OS

A-0

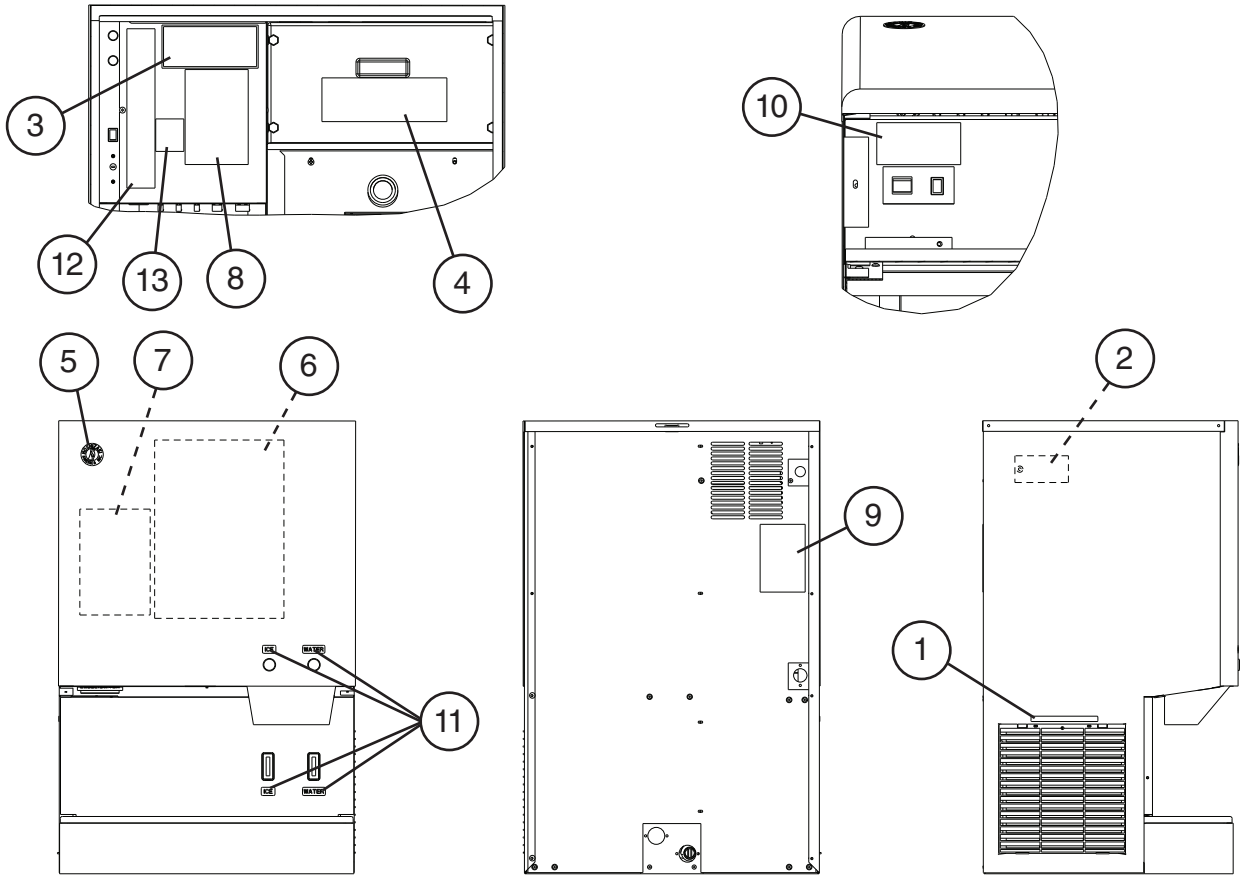

Title: J. Label Location		Model: DCM-300BAH, DCM-300BAH-OS		Required Number										
Index No.	Description	Material or Model Number	Part Number	A-0										
Label Location Order Assembly Parts Individually		DCM-300BAH	2A6511A01	1										
		DCM-300BAH-OS	2A6512A01	1										
1	Air Filter Label		426177-01	1										
2	Warning Tag: Electrical Connection		4A4766-01	1										
3	Warning Label		439149-01	1										
4	Bin Cover Instruction Sheet		446463-01	1										
5	Penguin-HA-R Label		456246-01	1										
6	Maintenance Label		2A6587-01	1										
7	Wiring Label	DCM-300BAH	3A6551-01	1										
		DCM-300BAH-OS	3A6552-01	1										
8	Rating Label	DCM-300BAH	3A6540-01	1										
		DCM-300BAH-OS	3A6540-02	1										
9	Nameplate	DCM-300BAH	3A6541-01	1										
		DCM-300BAH-OS	3A6541-02	1										
10	Switch Label		4A1038-01	1										
11	Ice-Water Label		4A2954-01	1										
12	Switch-Fuse Label		4A5352-01	1										
13	Warning Label		440683-01	1										

K. Accessories & Packaging
DCM-300BAH, DCM-300BAH-OS
 A-0

Title: K. Accessories & Packaging Model: DCM-300BAH, DCM-300BAH-OS											
Index No.	Description	Material or Model Number	Part Number	Required Number							
				A-0							
1	Instruction Manual		91A2AD10A	1							
	Packaging		1A0190G02								